

User Manual

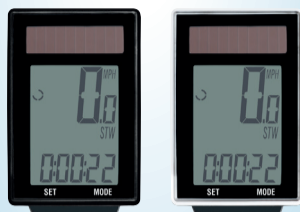

WIRELESS BICYCLE COMPUTER



DISTRIBUTED BY:
ALDI INC., BATAVIA, IL 60510
WWW.ALDI.US



3
YEAR
WARRANTY

AFTER SALES SUPPORT

95698

USA 866-558-8096

service@801service.net

MODEL:
22967

05/2018

General information Reading and storing the user manual

This user manual accompanies this wireless solar bicycle computer. It contains important information about start-up and use.

Before using the bicycle computer, read the user manual carefully. This particularly applies to the safety instructions. Failure to follow this user manual may result in severe injury, or damage to the bicycle computer. Store the user manual for further use. If you pass the bicycle computer on to third parties, please be absolutely sure to include this user manual.

Explanation of symbols

The following symbols and signal words are used in this user manual, on the bicycle computer or on the packaging.

WARNING!

This signal symbol/word designates a hazard with moderate degree of risk which may lead to death or severe injury if not avoided.

NOTICE!

This signal word warns against potential damages to property.



This symbol provides you with useful supplementary information about assembly or use.

FCC Conformity

This bicycle computer complies with part 15 of the FCC rules. Operation is subject to the following two conditions: (1) This device may not cause harmful interference, and (2) this device must accept any interference received, including interference that may cause undesired operation. Please take attention that changes or modification not expressly approved by the party responsible for compliance could void the user's authority to operate the equipment.

The operating frequency is between 120 kHz and 125 kHz.

Safety

Proper use

The bicycle computer is designed exclusively for displaying and collecting information when using a bicycle. It is only intended for private use and not suitable for commercial purposes.

Only use the bicycle computer as described in this user manual. Using it in any other way is deemed improper and may result in damage to property or even personal injury. The bicycle computer is not a children's toy.

The manufacturer or vendor accepts no liability for damage caused by improper or incorrect use.

Safety instructions

WARNING!

Danger for children and persons with impaired physical, sensory or mental capacities (e.g. partially disabled persons, older persons with reduced physical and mental capacities) or lack of experience and knowledge (e.g. older children).

- This bicycle computer may be used by children ages eight and over as well as persons with impaired physical, sensory or mental capacities or those lacking experience and knowledge, if they are supervised or have been instructed in how to safely use the bicycle computer and understand the risks associated with operating it. Children must not play with the bicycle computer. Cleaning and user maintenance must not be performed by unsupervised children.
- Keep children under eight years of age away from the bicycle computer.

WARNING!

Danger of suffocation!

The bicycle computer contains small parts. Children could swallow them when playing and choke.

- Keep small parts away from children.

WARNING!

Battery hazards!

The bicycle computer and the sensor each contain a battery. Improper handling of the batteries may result in explosion or serious internal injury.

- Store both new and used batteries so that they are not accessible to children.
- If you suspect that a battery has been swallowed or otherwise incorporated, promptly consult a physician.
- Only replace the batteries with the same battery type.
- Do not touch leaky batteries. If you do come into contact with battery acid, wash the affected area thoroughly and rinse it with plenty of water. If leaked battery acid comes into contact with your eyes or causes skin irritation, also seek medical attention.
- If it is no longer possible to securely close the battery compartment, dispose of the bicycle computer as described in the chapter "Disposal".
- Do not charge or reactivate batteries, do not disassemble them, do not throw them in fire and do not short circuit them.
- Dispose of batteries at your local collection point.

NOTICE!

Risk of damage!

- Improper handling of the bicycle computer may result in damage to the bicycle computer.
- You can use the bicycle computer at ambient temperatures between 14 °F and 122 °F (-10 °C and +50 °C).
- Do not expose the bicycle computer to permanent moisture.

Selecting kilometers/ miles

The selection for the units of measure kilometers (KM/H) or miles (MPH) will appear as the first indicator.

- Press the right button **3** to switch between the units of measure.
- Confirm your selection by pressing the left button **4**.

Setting tire circumference

Necessary after new battery insertion or reboot.

How to determine the tire circumference:

1. Turn the front tire valve to the lowest position and mark the position of the valve on the floor.
2. Move the bicycle forward for one front wheel revolution until the valve has returned to the lowest position.
3. Measure the distance covered in inches.

This is the tire circumference.

The display shows the default setting for a "2155" tire circumference (=mm). The thousands digit 2 flashes. The thousands digit can be set to either 1 or 2. The remaining numbers can assume a value between 0-9.

- Press the right button **3** until the correct number appears.

The thousands digit is set.

- Confirm your entry by pressing the left button **4**.
- Repeat the steps for the hundreds, tens and ones.

Setting the total distance

The display shows the default setting for a total distance of "00000".

- Press the right button **3** to increase the number by one.
- Confirm your entry by pressing the left button **4**.

The ones, tens, hundreds, thousands and ten thousands can assume a value between 0-9.

Setting the inspection interval

The display will show the default setting of "000.00" for the total distance. This corresponds to the remaining distance until the next bike inspection.

- Press the right button **3** to increase the ones, tens or hundreds by one.
- Confirm your entry by pressing the left button **4**.

Setting weight

The display will show a default setting of "065" for weight.

- Press the right button **3** to increase the hundreds, tens or ones by one.
- Confirm your entry by pressing the left button **4**.

Setting the CO₂ savings

This function calculates the CO₂ savings. This determines how much CO₂ would have been produced if the journey had been made by car rather than by bicycle. Look in the technical documents of your car to find its emissions value in g/km. Or use the default setting of 160 g/km. The default value of "160" appears.

- Press the right button **3** to increase the hundreds, tens or ones by one.
- Confirm your entry by pressing the left button **4**.

Setting the time

The hour display flashes.

- Press the right button **3** until the correct number appears.

The hour display is set.

- Confirm your entry by pressing the left button **4**.

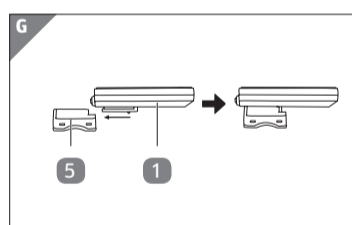
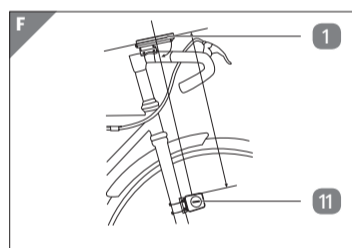
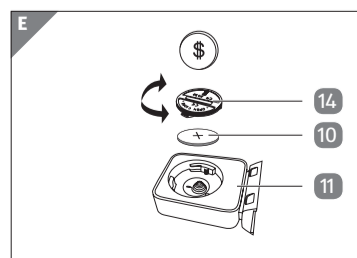
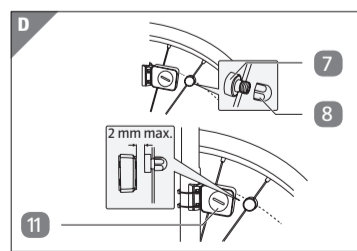
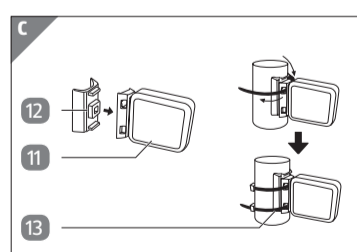
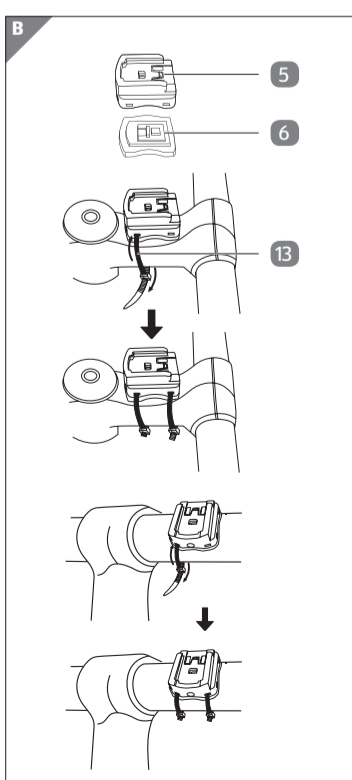
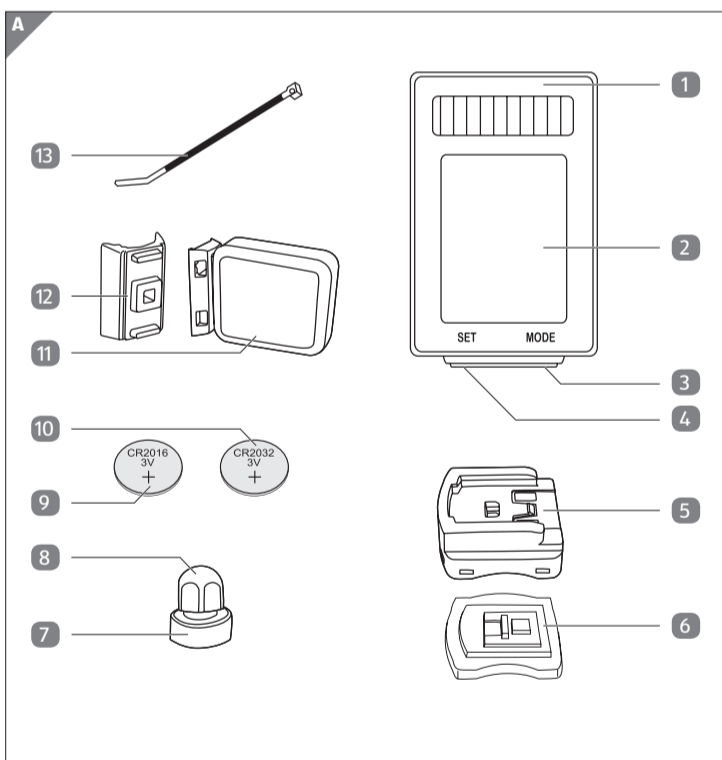

Package contents/ device parts

- 1 Bicycle computer (example)
- 2 Display
- 3 Right button
- 4 Left button
- 5 Bicycle computer mounting bracket
- 6 Rubber pad (bicycle computer)
- 7 Magnet
- 8 Magnet holder
- 9 CR2016 battery
- 10 CR2032 battery
- 11 Sensor
- 12 Rubber pad (sensor)
- 13 Cable ties, 6x
- 14 Battery compartment cover

The minute display flashes.

- Press the right button **3** until the correct number appears.

The minute display is set.

- Confirm your entry by pressing the left button **4**.

Setting the backlight

You can choose between LT-1 and LT-2 mode.

LT1-1 mode:

The backlight will be activated for approx. 3 seconds as soon as any button is pressed in any mode within the set time frame.

LT2 MODE:

The backlight will turn on or off if the right button **3** is held down for approx. 3 seconds.

Setting:

The LT-1 mode indicator flashes on the display.

- Press the right button **3** to switch between LT-1 mode and LT-2 mode.
- Confirm your entry by pressing the left button **4**.

After you have confirmed LT-2 mode, the main function indicator will appear.

After you have confirmed LT-1 mode, you will set the time frame (start and stop time) for activating the backlight.

The hour display flashes.

- Press the right button **3** until the correct number appears.

The hour display is set.

- Confirm your entry by pressing the left button **4**.

The minute display flashes.

- Press the right button **3** until the correct number appears.

The minute display is set.

- Confirm your entry by pressing the left button **4**.

Testing the bicycle computer

- Turn the front wheel of the bicycle.

The speed appears in the display **2** if the bicycle computer **1**, sensor **11** and magnet **7** have been correctly mounted. If the speed does not appear in the display, check and repeat the assembly procedure if necessary (see chapter "Assembly").

Restarting bicycle computer

- To reset stored data, press the left button **4** and right button **3** together for approx. 5 seconds.

After restarting/resetting the device, all settings must be reentered (see section "Setting tire circumference" to section "Setting the time").

Automatic power-off of the bicycle computer

When at a standstill, the bicycle computer automatically powers off after approx. 5 minutes without loss of data.

- To switch the bicycle computer **1** back on again, press the right button **3** or the left button **4**.

Automatic stop-start function

All functions have an automatic start-stop function (exception: stopwatch and time).

- To activate this stop-start function, first switch on the bicycle computer **1** by pressing the left button **4** or the right button **3**.

Measuring starts when the magnet **7** passes the sensor **11** for the first time. If the bicycle is still, it waits approx. 3 seconds for a new signal. If there is no further signal, the measuring process stops automatically.

Modes/functions

The speed and time indicator appears after the bicycle computer has started up (see **Fig. H**).

Speed

- This is constantly calculated and updated; it is always shown in the middle of the display **2**. Max. measuring range: up to 199.9 km/h / mph.

CLK (time) / SCAN

- The time is shown in 24-hour mode. It is set as described in the section "Setting the time".
- Press the left button to access the SCAN function.

The word SCAN appears in the bottom left of the display. In this mode, the functions DST, TM, and AV SPD are automatically displayed at a 2 second interval.

- Press the left button to switch back to time.
- Press the right button to switch to the stopwatch.

STW (Stopwatch)

- Press the left button to start/stop the stopwatch. Maximum measuring range: 9:59:59.
- Press the right button to switch to trip distance.

DST (distance)

The counter for trip distance will automatically start when you start cycling.

Maximum measuring range: 999.99.

- Press the left button to switch between the trip distance and total distance.
- Press the right button to switch to the cycling time indicator.

TOT DST (total distance)

The total kilometers (miles) cycled are saved.

Maximum measuring range: 99999.

- Press the right button to switch to the cycling time indicator.

TM (cycling time)

The total cycling time since the last reboot is shown. Maximum measuring range: 9:59:59.

- Press the right button to switch to the average speed.

AV SPD (average speed)

Maximum measuring range: 199.9 km/h or mp/h.

- Press the left button to switch between the average and maximum speed.
- Press the right button to switch to calorie counter.

MX SPD (maximum speed)

The maximum speed reached is stored.

Maximum measuring range: 199.9 km/h or mp/h.

- Press the right button to switch to calorie counter.

CAL (calorie counter)

The average calories burned (kcal) are shown.

Maximum measuring range: 999.9.

- Press the left button to switch between the calorie counter, total calories burned and the fat burning meter.
- Press the right button to switch to the temperature.

TOTCAL (total calories burned)

The total calories burned (kcal) since the last reboot is shown.

Maximum measuring range: 99999.

- Press the right button to switch to the temperature.

FAT (fat burning meter)

The average amount of fat burned is shown in grams.

Maximum measuring range: 999.9.

- Press the right button to switch to the temperature.

TEP (temperature)

The temperature is measured and updated approx. every 2 minutes.

- Press the left button to switch between the current, maximum and minimum temperature measured.

- Hold the left button for the current temperature indicator for approx. 5 seconds to switch to °F (Fahrenheit).

- Press the right button to switch to the time.

Speed comparison

Cycling faster or slower than the average speed up to this point will be shown with \circ or ∇ on the top left next to the speed indicator.

Resetting data

(AV SPD, MX SPD, TOTCAL, STW, DST, TOT DST, TM)

- Press the right/left button until the corresponding function is shown.
- Hold the left button down for approx. 3 seconds to reset the value.

Changing the battery

1. Open the battery compartment of the bicycle computer **1** or sensor **11** by turning the battery compartment cover **14** counterclockwise with a coin (see **Fig. E**).
2. Remove the depleted battery **9** or **10** using a pointed object.
3. Insert a new battery so that the positive pole (+) is facing upward.
4. Replace the battery compartment cover.
5. Close the battery compartment by turning the battery compartment cover clockwise with a coin (see **Fig. E**).
6. Start the bicycle computer and enter the settings again (see section "Selecting kilometers/miles" to section "Setting the backlight").

Cleaning and maintenance

NOTICE!

Risk of short circuit!

Liquid that has penetrated the housing may cause a short-circuit.

- Never immerse the bicycle computer in liquids.
- Make sure that no liquid penetrates the housing.

NOTICE!

Risk of damage!

Improper cleaning can damage the bicycle computer.

- Do not use any aggressive cleaners, brushes with metal or nylon bristles as well as sharp or metallic cleaning utensils such as knives, hard scrapers or the like. They could damage the surfaces.

Watertightness

Your bicycle computer is protected against splashing water, please do not submerge in water.

- Only clean with a damp cleaning cloth and wipe dry afterwards.

Storage

All parts must be completely dry before storage.

- Always store the bicycle computer **1** in a dry area.
- Protect the bicycle computer from direct sunlight.
- Store the bicycle computer so that it is not accessible to children, securely locked away and at a storage temperature between 14 °F and 122 °F (-10 °C and 50 °C) (room temperature).

Troubleshooting

No speed display:

- Check the alignment of the sensor **11** and magnet **7**.
- Check the distance between the magnet and sensor (max. 0.08" (2 mm)) as well as the distance and angle between the bicycle computer **1** and sensor (90°/max. 23" (60 cm)).
- Check the battery **9** and **10** of the bicycle computer and sensor.
- Replace the battery.

Incorrect speed measurement:

- Check the setting of the tire circumference.
- Check the kilometers/miles setting.
- Check the alignment of the sensor and magnet.

Black display:

- Check whether the display **2** has become too hot. Allow it to cool down.

Display shows irregular digits:

- Remove the battery and insert it again while making sure that the polarity is correct.

Weak or no display:

- Check that the battery is properly inserted.
- Replace the battery.

Technical data

Model:	22967
Operating voltage:	3 V 
Sensor battery:	CR2032
Computer battery:	CR2016
Protection class:	IP44
Weight:	approx. 0.13 lb (57 g)
Dimensions (W × D × H):	1.5 × 2.4 × 0.6" (3.9 × 6.2 × 1.5 cm)
Article number:	95698

Disposal

Disposing of the packaging

- Sort the packaging before you dispose of it. Dispose of paperboard and cardboard with the recycled paper service and wrappings with the appropriate collection service.

Disposing of the bicycle computer

- Should the bicycle computer no longer be capable of being used at some point in time, **dispose of it in accordance with the regulations in force in your city or state.**
- Please ensure your recycling information applies to local regulations and the EPA recommendations (www.epa.gov).

Batteries and rechargeable batteries must not be disposed of with household waste!

As the end user you are required by law to bring all batteries and rechargeable batteries, regardless whether they contain harmful substances* or not, to a collection point run by the communal authority or borough or to a retailer, so that they can be disposed of in an environmentally friendly manner.

The battery must be removed from the bicycle computer before disposal.

*labelled with: Cd = cadmium, Hg = mercury, Pb = lead